

MAGNAPLAST INSPECTION CHAMBER



TYPE 400

INSPECTION CHAMBER COMPONENTS:

- Chamber base with seal, profiled bottom, and branch ports (if any)
- Rising pipe
- Telescope (telescopic pipe complete with a cast-iron chamber cover)
- Casing end seal

CHAMBERS BASE TYPE 400 STRAIGHT WITH SEAL

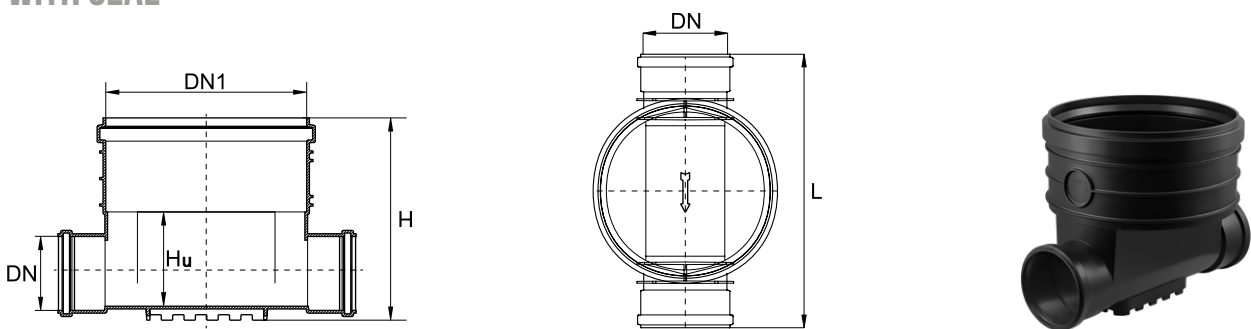

DN [mm]	DN1 [mm]	H [mm]	Hu [mm]	L [mm]	Product no.
110	400	351	355	456	34100
160	400	432	205	590	34130
200	400	401	410	509	34215
250	400	530	293	710	34235
315	400	800	540	1080	34325

CHAMBER BASE TYPE 400 3 INLETS WITH SEAL

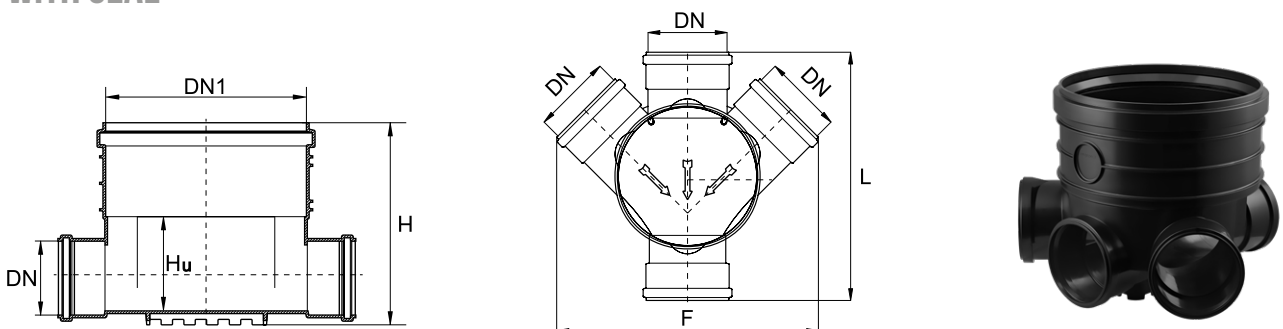

DN [mm]	DN1 [mm]	H [mm]	Hu [mm]	L [mm]	F [mm]	Product no.
110	400	352	335	456	550	34110
160	400	432	205	536	600	34115
200	400	402	410	509	660	34210
250	400	800	545	1130	1130	34220
315	400	800	545	1080	1130	34310